

Water cooled series

8~36HP (22.4~100.0kW)

Production by order

Model No.	Nominal Cooling Capacity	Model No.	Nominal Cooling Capacity
FDC224KXZWE1	22.4kW	FDC730KXZWE1(FDC224×2+FDC280)	73.0kW
FDC280KXZWE1	28.0kW	FDC775KXZWE1(FDC224+FDC280×2)	77.5kW
FDC335KXZWE1	33.5kW	FDC850KXZWE1(FDC280×3)	85.0kW
FDC450KXZWE1(FDC224×2)	45.0kW	FDC900KXZWE1(FDC280×2+FDC335)	90.0kW
FDC500KXZWE1(FDC224+FDC280)	50.0kW	FDC950KXZWE1(FDC280+FDC335×2)	95.0kW
FDC560KXZWE1(FDC280×2)	56.0kW	FDC1000KXZWE1(FDC335×3)	100kW
FDC615KXZWE1(FDC280+FDC335)	61.5kW		
FDC670KXZWE1(FDC335×2)	67.0kW		

Features

1. High efficiency (EER/COP)

- Energy saving → Reduction of operation cost

2. Compact design

- Easy transportation and installation
- Carriable by elevator

3. BMS (Building Management System)

- Can use the same BMS as air cooled KX
- Available to large-scale and fine control

4. Serviceability & Maintenance

- Service and maintenance of main parts can be done from the front side only
- Useful service tools (Mente-PC, SL-Checker etc.)

Applicable to

1. High-rise Building

- 50m <FDC> , -100m <FDCH>
- 100m or higher in height <FDCW>

2. Glass-exterior facade Building

- Possible to hide KXZW units and to keep fine sight



Specifications

Item	Model	FDC224KXZWE1	FDC280KXZWE1	FDC335KXZWE1	FDC450KXZWE1	FDC500KXZWE1	FDC560KXZWE1	FDC615KXZWE1	FDC670KXZWE1	
Combination (FDC)		-	-	-	224KXZWE1	224KXZWE1	280KXZWE1	280KXZWE1	335KXZWE1	
Nominal horse power		8HP	10HP	12HP	16HP	18HP	20HP	22HP	24HP	
Power source		3 Phase 380-415V, 50Hz								
Nominal capacity	Cooling	22.4	28.0	33.5	45.0	50.0	56.0	61.5	67.0	
	Heating	25.0	31.5	37.5	50.0	56.0	63.0	69.0	75.0	
Power consumption	Cooling	4.23	5.75	8.13	8.49	9.83	11.5	13.7	16.3	
	Heating	4.24	5.10	6.30	8.47	9.27	10.2	11.4	12.6	
EER	Cooling	5.3	4.9	4.1	5.3	5.1	4.9	4.5	4.1	
COP	Heating	5.9	6.2	6.0	5.9	6.0	6.2	6.1	6.0	
Exterior dimensions	HxWxD	1100x780x550				(1100x780x550)x2				
Sound pressure level	dB(A)	48	50	52	51	52	53	54	55	
Net weight	kg	185				185x2				

Item	Model	FDC730KXZWE1	FDC775KXZWE1	FDC850KXZWE1	FDC900KXZWE1	FDC950KXZWE1	FDC1000KXZWE1
Combination (FDC)		224KXZWE1	224KXZWE1	280KXZWE1	280KXZWE1	280KXZWE1	335KXZWE1
Nominal horse power		26HP	28HP	30HP	32HP	34HP	36HP
Power source		3 Phase 380-415V, 50Hz					
Nominal capacity	Cooling	73.0	77.5	85.0	90.0	95.0	100
	Heating	82.5	90.0	95.0	100	106	112
Power consumption	Cooling	14.2	15.5	17.5	19.5	21.7	24.3
	Heating	13.8	14.8	15.4	16.4	17.6	18.8
EER	Cooling	5.1	5.0	4.9	4.6	4.4	4.1
COP	Heating	6.0	6.1	6.2	6.1	6.0	6.0
Exterior dimensions	HxWxD	(1100x780x550)x3					
Sound pressure level	dB(A)	54	54	55	56	56	57
Net weight	kg	185x3					

The data are based on the rating condition:

Cooling: Indoor temp. of 27 °C DB, 19 °C WB, and heat source unit inlet water temp. of 30 °C, water flow rate 96 L/min
 Heating: Indoor temp. of 20 °C DB, 15 °C WB, and heat source unit inlet water temp. of 20 °C, water flow rate 96 L/min

Heat source units on every floor
- New building projects -

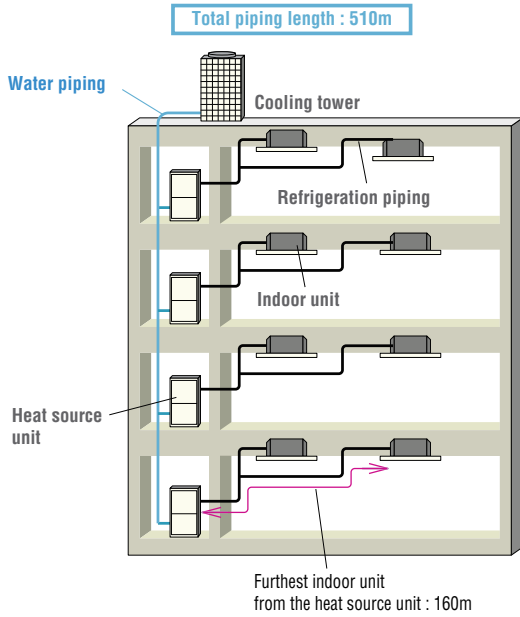

Heat source units in the machine room
- Renovation projects -

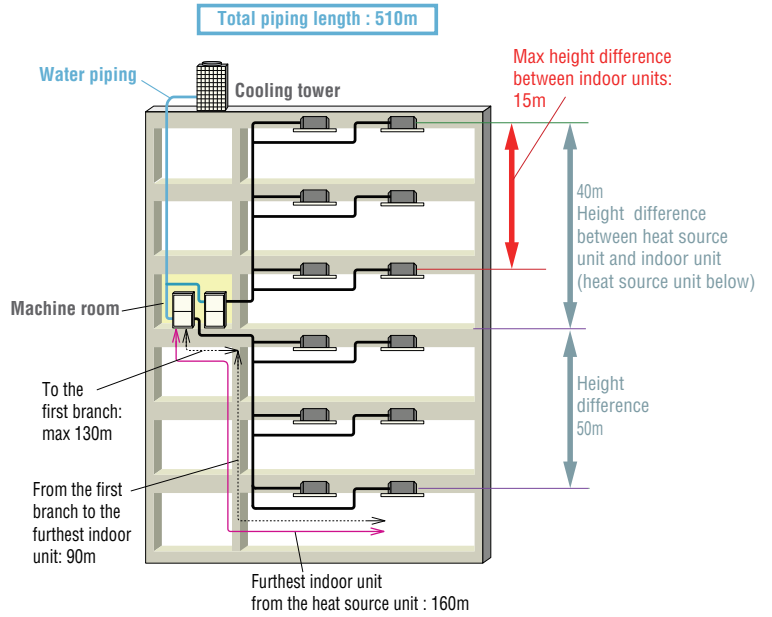

Dimensions

All measurements in mm.

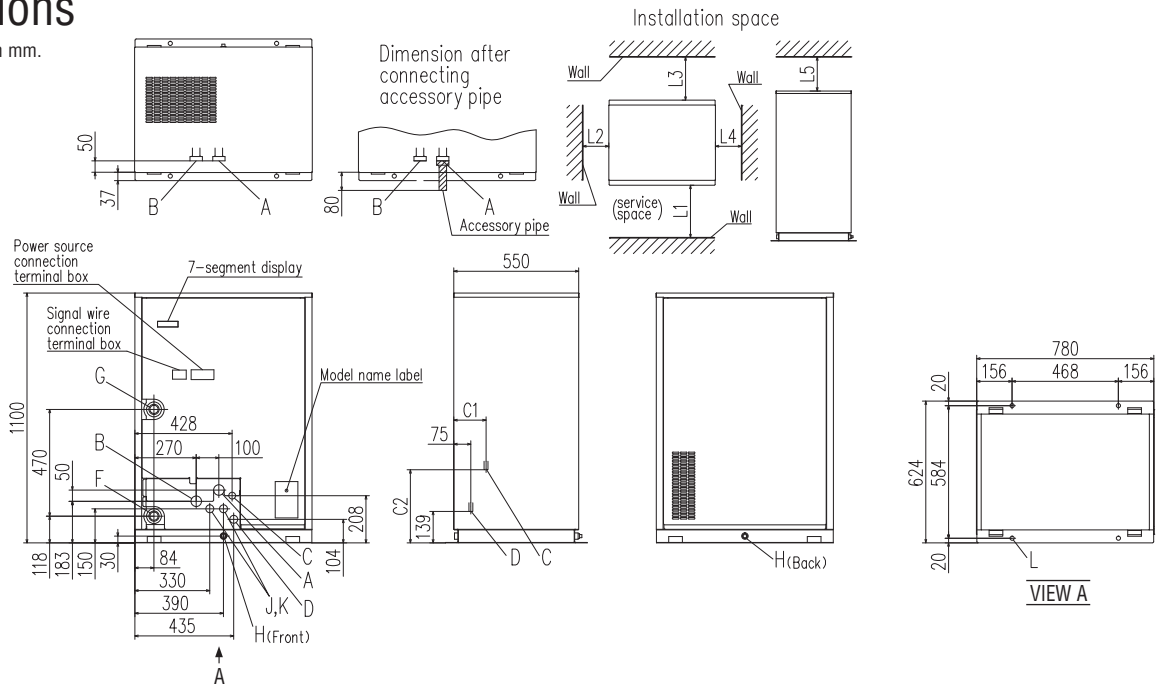

Mark	Content	
A	High/low gas line	Refer to piping size
B	-	Not to use.
C	Liquid line	Refer to piping size
D	Oil equalization line	
F	Water inlet	R1 1/4
G	Water outlet	R1 1/4
H	Drain outlet	Rp 1/2,2places
J	Power source intake	ø35
K	Signal wiring intake	ø35
L	Anchor bolt hole	ø18,4places

Dimension	FDC-KXZWE1	
		224,280
C1	142	139
C2	322	316
Dimension	Installation example	1
	L1	600 or more
L2	20 or more	
L3	500 or more	
L4	20 or more	
L5	300 or more	

Piping size

	FDC224KXZWE1	FDC280KXZWE1	FDC335KXZWE1	Connection method
High/low gas line	ø19.05	ø22.22	ø25.4	Flange
Liquid line	ø9.52	ø9.52	ø12.7	Flare
Oil equalization line	ø9.52	ø9.52	ø9.52	